



NAMI | Bath

WITH **OLOS**  
BY CERAMICHE "CESAR"





# INDICE

Index

FREE-STANDING

**FT01 TOTEM** 06

TOP LAVABI CON VASCA INTEGRATA / WASHBASIN  
WITH INTEGRATED SINK / LAVABO AVEC BAC INTEGRÉ

**LS01 SLIM** 10

**LY01 SIMPLY** 12

**LM01 STEEL BOTTOM** 14

**LB01 BASIC** 18

**LT01 TWOSIDE** 20

PIANI LAVABO E TOP LAVABI IN APPOGGIO / VANITY TOP  
AND WASHBASIN / PLAN SANS BAC ET LAVABO À POSER

**L001 PLANO** 26

**AP01 PRISM** 28

**AW01 WASH HOUSE** 30

**AF01 FOLD** 34

PIATTI DOCCIA / SHOWER TRAY / RECEVEUR DE DOUCHE

**PC01 SIGN** 40

**PS01 CORNER** 42





# NAMI Bath

WITH **OLOS**  
BY CERAMICHE CAESAR

Solidità, affidabilità, design accattivante: questi i tratti distintivi degli elementi per l'arredobagno di NAMI. L'attuale collezione spazia dal concetto - rielaborato e modernizzato - dell'antico lavabo in pietra, fino a forme più essenziali e contemporanee.

L'esperienza più che ventennale dell'azienda viene arricchita dalla collaborazione con OLOS, il brand di Ceramiche Caesar (primario produttore di grès porcellanato made in Italy) che nasce per valorizzare l'utilizzo delle lastre in grès come finitura d'arredo: questa sinergia mette a disposizione di NAMI un materiale esteticamente e tecnicamente all'avanguardia.

Sviluppate con le più recenti tecnologie, le grandi lastre fornite da Ceramiche Caesar offrono un ampio ventaglio di look e la possibilità di avere arredi coordinati con pavimenti e rivestimenti. In più questo materiale garantisce agli arredi NAMI facile manutenzione e inalterabilità nel tempo.

NAMI possiede tutte le tecnologie e l'esperienza per lavorare il grès: l'elevato grado di industrializzazione raggiunto, sommato alla passione artigianale che contraddistingue il lavoro quotidiano, consente di fornire un mix di prodotto cucito su misura sulle esigenze del cliente, sia con elementi standard, sia con soluzioni personalizzate.

Solidity, reliability, an appealing design: these are the unique features of NAMI bathroom furniture. The current collection draws inspiration from traditional stone washbasins - appropriately re-elaborated and updated - and more minimal and contemporary shapes.

The over twenty years of experience of the company are now enriched by the partnership with OLOS, the Ceramiche Caesar (leading manufacturer of Made in Italy porcelain stoneware) brand created for promoting the use of porcelain stoneware as furniture finishing material: this synergy offers NAMI a material that is aesthetically and technically at the forefront.

Developed using the latest technology, the extra large slabs supplied by Ceramiche Caesar offer a variety of different looks and the possibility to match furniture with floor and wall coverings. As an added feature, this material offers NAMI furniture easy maintenance properties and durability over time.

NAMI has all the technology and experience needed to process stoneware: the high standard of industrialisation reached and the passion for one's daily work has led to a product that is tailor-made for the customer's needs, both when it comes to standard elements and to customised solutions.

Solidité, fiabilité, design attrayant : telles sont les caractéristiques des éléments de décoration pour salles de bains de NAMI. La collection actuelle comprend des objets qui vont du concept - réinterprété et modernisé - de l'ancien lavabo en pierre aux formes plus essentielles et contemporaines.

Les plus de vingt ans d'expérience de l'entreprise s'enrichissent aujourd'hui du partenariat avec OLOS, la marque de Ceramiche Caesar (l'un des principaux producteurs de grès cérame made in Italy), qui permet de valoriser l'utilisation des dalles en grès cérame comme finition de décoration : cette synergie met à la disposition de NAMI un matériau à l'avant-garde d'un point de vue aussi bien esthétique que technique.

Développées avec les dernières technologies, les grandes dalles fournies par Caesar offrent un large choix d'aspects et la possibilité d'avoir des décorations coordonnées avec les revêtements de sols et de murs. De plus, ce matériau garantit aux décorations NAMI un entretien facile et l'inaltérabilité dans le temps.

NAMI dispose de toutes les technologies et d'une grande expérience dans le travail du grès cérame : le haut degré d'industrialisation, combiné à la passion artisanale qui caractérise le travail quotidien, permet de fournir une série de produits adaptés aux besoins du client, aussi bien avec des articles standards qu'avec des solutions personnalisées.





FREE-STANDING  
Free-standing



TOTEM  
FREESTANDING  
TOTEM



# FT01 TOTEM

design Roberto Semprini

Lavello free standing con struttura in gres accoppiato.  
Scarico centrale. Elementi laterali opzionali realizzati in legno TEAK.

Free standing washbasin with coupled porcelain stoneware structure.  
Central drain. Optional side elements made of TEAK.

Lavabo free standing avec structure en grès accouplé.  
Evacuation centrale. Éléments latéraux en option réalisés en TEAK.

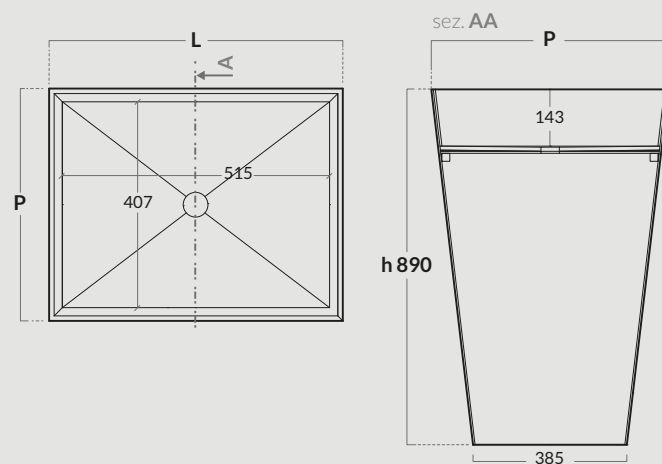

DIMENSIONI / DIMENSIONS / DIMENSIONS

LAVABO  
WASHBASIN  
LAVABO

ANIMA STATUARIO VENATO  
SILK



PAVIMENTO  
FLOOR  
SOL

ANIMA STATUARIO VENATO  
NATURALE/MATT



120x120 cm  
47 2/8" x 47 2/8"

RIVESTIMENTO  
WALL TILING  
REVÊTEMENT

HIKE NUANCE  
NATURALE



30x240 cm  
11 13/16" x 94 1/8"

ANIMA STATUARIO VENATO  
LUCIDATO



30x60 cm  
11 13/16" x 23 5/8"

Un Totem domestico dallo stile minimale. La sua forma a trapezio risalta in tutta la sua purezza con la ceramica, mentre in alto spuntano due ali in TEAK come a voler offrire altre funzioni slanciandone la silhouette.

A minimal free-standing Totem Its trapezoid shape is enhanced by the pureness of the ceramic, while two top teak wooden wings come out of the totem offering new functions and elongating its silhouette.

Un Totem domestique au style minimaliste. Sa forme en trapèze et sa céramique mettent en valeur toute sa pureté tandis qu'un peu plus haut, apparaissent deux ailes en TEAK qui élancent sa silhouette afin d'offrir d'autres fonctions.



# TOP LAVABI CON VASCA INTEGRATA

Washbasin with integrated sink / Lavabo avec bac intégré







LAVABO A MURO  
WALL-HUNG WASHBASIN  
LAVABO MURAL



# LS01 SLIM

design **Studio interno Nami**

**Top lavabo a muro o in appoggio con misure personalizzabili.  
Struttura in pannelli alleggeriti. Vasca inox integrata con scarico lineare.**

Wall-hung or countertop washbasin with customizable sizes.  
Structure based on lightened panels. Integrated stainless steel basin with linear drain.

Lavabo mural ou à poser sur meuble aux mesures personnalisées.  
Structure en panneaux allégés. Bac en inox intégré avec écoulement linéaire.

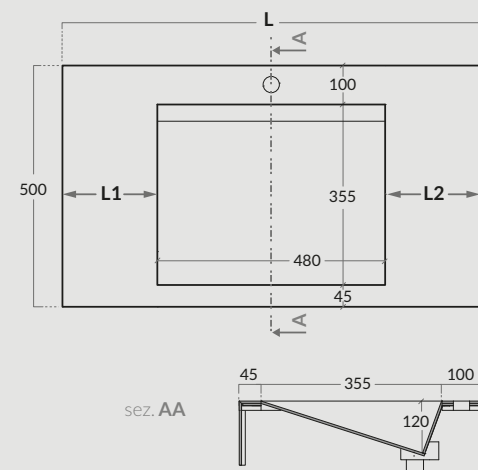

DIMENSIONI / DIMENSIONS / DIMENSIONS

LAVABO / MENSOLA  
WASHBASIN / SHELF  
LAVABO / ÉTAGÈRE

RELATE REEF (FLAME)  
NATURALE/MATT



PAVIMENTO  
FLOOR  
SOL

RELATE WIND BRUSH  
NATURALE/MATT

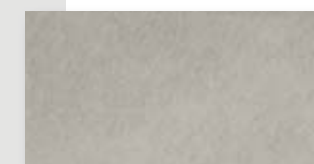

60x120 cm  
23<sup>5/8</sup>" x 47<sup>2/8</sup>"

RIVESTIMENTO  
WALL TILING  
REVÊTEMENT

RELATE REEF (FLAME)  
NATURALE/MATT



120x240 cm  
47<sup>1/16</sup>" x 94<sup>1/8</sup>"

RELATE WIND BRUSH  
NATURALE/MATT

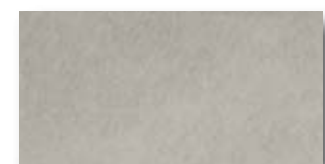

60x120 cm  
23<sup>5/8</sup>" x 47<sup>2/8</sup>"

**Elegante, semplice e lineare genera un'atmosfera sofisticata e accogliente.**

Elegant, simple and linear, it generates warm and sophisticated sensations.

Élégant, simple et linéaire, il génère une atmosphère sophistiquée et accueillante.



# LY01 SIMPLY

design **Studio interno Nami**

**Top lavabo a muro o in appoggio con misure personalizzabili. Struttura in pannelli alleggeriti. Vasca inox integrata con scarico lineare posteriore.**

Wall-hung or countertop washbasin with customizable sizes. Structure based on lightened panels. Integrated stainless steel basin with rear linear drain.

Lavabo mural ou à poser sur meuble aux mesures personnalisées. Structure en panneaux allégés. Bac inox intégré avec écoulement linéaire arrière.



LAVABO A MURO  
WALL-HUNG WASHBASIN  
LAVABO MURAL

LAVABO  
WASHBASIN  
LAVABO

JOIN WING  
NATURALE/MATT

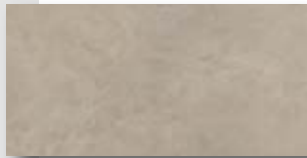

PAVIMENTO  
FLOOR  
SOL

ANIMA CALACATTA ORO  
NATURALE/MATT



120x120 cm  
47 2/8 x 47 2/8"

RIVESTIMENTO  
WALL TILING  
REVÊTEMENT

BEMORE HAZE  
NATURALE/MATT



160x320 cm  
63" x 126"

**Lavabo che si distingue per la semplicità delle forme e per la possibilità di adattarsi a qualsiasi esigenza sia nelle dimensioni del piano che della vasca.**

This washbasin is characterized by simple shapes. It can be easily adapted to any kind of environment, both in terms of top and basin dimensions.

Lavabo qui se distingue par la simplicité de ses formes et pour s'adapter à toutes exigences aussi bien dans les dimensions du plan que de la vasque.

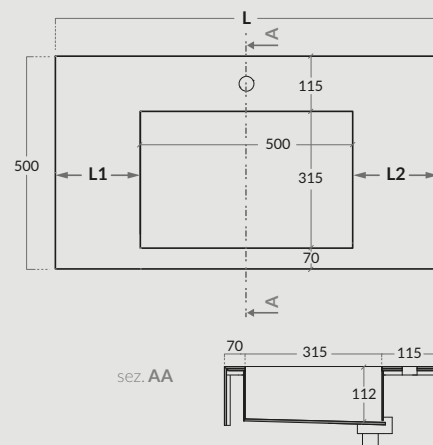

DIMENSIONI / DIMENSIONS / DIMENSIONS



LAVABO A MURO  
WALL-HUNG WASHBASIN  
LAVABO MURAL



## LM01 STEEL BOTTOM

design **Studio interno Nami**

La doppia personalità della vasca caratterizzata da linee semplici permette di mantenere nascosto lo scarico accentuando l'eleganza dell'elemento.

The double personality of the basin characterized by simple lines allows to hide the drain enhancing the elegance of the product.

La double personnalité du bac se caractérise par des lignes simples qui permettent de tenir cachés les tuyaux d'évacuation en accentuant l'élégance de l'élément.

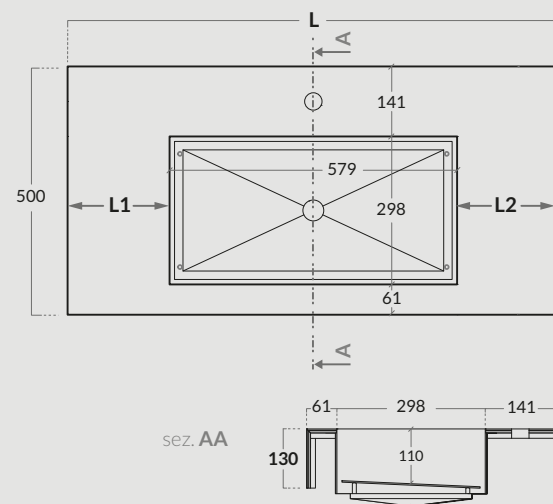

DIMENSIONI / DIMENSIONS / DIMENSIONS

LAVABO  
WASHBASIN  
LAVABO

ANIMA EVER INVISIBLE LIGHT  
NATURALE/MATT



PAVIMENTO  
FLOOR  
SOL

ANIMA EVER INVISIBLE LIGHT  
NATURALE/MATT

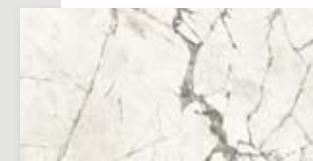

120x120 cm  
47<sup>2</sup>/<sub>8</sub>x47<sup>2</sup>/<sub>8</sub>"

RIVESTIMENTO  
WALL TILING  
REVÊTEMENT

JOIN LEVITY  
NATURALE/MATT



120x278 cm  
47<sup>1</sup>/<sub>16</sub>x109<sup>1</sup>/<sub>8</sub>"

Top lavabo a muro o in appoggio con misure personalizzabili. Struttura in pannelli alleggeriti. Vasca inox integrata con scarico centrale e copri-piletta.

Wall-hung or countertop washbasin with customizable sizes. Structure based on lightened panels. Integrated stainless steel basin with central drain and drain cover.

Lavabo mural ou à poser sur meuble aux mesures personnalisées. Structure en panneaux allégés. Bac inox intégré avec évacuation centrale et bonde.







LAVABO A MURO  
WALL-HUNG WASHBASIN  
LAVABO MURAL



## LB01 BASIC

design **Studio interno Nami**

**Top lavabo a muro o in appoggio con misure personalizzabili.  
Struttura in pannelli alleggeriti. Vasca inox integrata con scarico centrale.**

Wall-hung or countertop washbasin with customizable sizes.  
Structure based on lightened panels. Integrated stainless steel basin with central drain.

Lavabo mural ou à poser sur meuble aux mesures personnalisées.  
Structure en panneaux allégés. Bac inox intégré avec écoulement central.

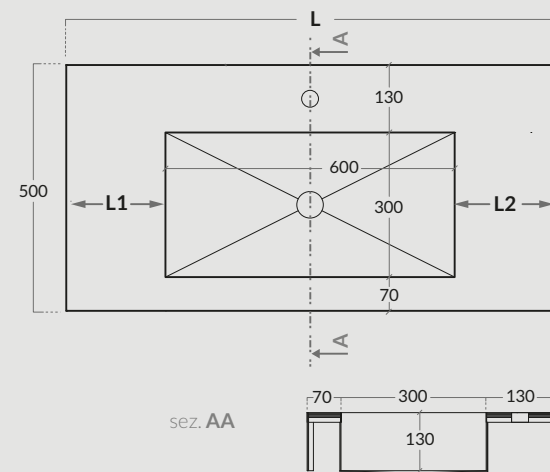

DIMENSIONI / DIMENSIONS / DIMENSIONS

LAVABO  
WASHBASIN  
LAVABO

PORTRAITS COMBLANCHIEN  
NATURALE/MATT



PAVIMENTO  
FLOOR  
SOL

RELATE MINE  
NATURALE/MATT



120x120 cm  
47<sup>2/8</sup> x 47<sup>2/8</sup>"

RIVESTIMENTO  
WALL TILING  
REVÊTEMENT

PORTRAITS COMBLANCHIEN  
NATURALE/MATT



120x120 cm  
47<sup>2/8</sup> x 47<sup>2/8</sup>"

RELATE MINE  
NATURALE/MATT



120x278 cm  
48" x 109<sup>25/64</sup>"

**Lavabo con vasca rettangolare facilmente adattabile  
ad ogni esigenza e ambiente.**

This washbasin is equipped with a rectangular basin  
suitable for any need or environment.

Lavabo avec vasque rectangulaire adaptable à toutes  
exigences et ambiances



# LI01 TWOSIDE

design **Studio Solido**

**Top lavabo a muro con misure personalizzabili. Struttura in pannelli alleggeriti. Vasca inox integrata con scarico centrale.**

Wall-hung or countertop washbasin with customizable sizes. Structure based on lightened panels. Integrated stainless steel basin with central drain.

Lavabo version mural ou à poser sur meuble aux mesures personnalisées. Structure en panneaux allégés. Bac en inox intégré avec évacuation centrale.

LAVABO A MURO  
WALL-HUNG WASHBASIN  
LAVABO MURAL



LAVABO  
WASHBASIN  
LAVABO

TRACE MINT  
NATURALE/MATT



PAVIMENTO  
FLOOR  
SOL

TRACE MINT  
NATURALE/MATT



120x240 cm  
47 1/16" x 94 1/8"

RIVESTIMENTO  
WALL TILING  
REVÊTEMENT

EVOOD PAINT  
NATURALE/MATT

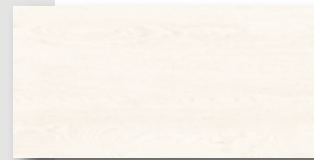

20x120 cm  
47 2/8" x 7 7/8"

**Top lavabo con vasca integrata ottenuta da due pareti inclinate contrapposte a due perpendicolari, dotato di un bordo funzionale utilizzabile per l'installazione di un miscelatore da piano, oppure come comodo piano da appoggio.**

Countertop washbasin with integrated basin obtained with two slanted walls and two perpendicular walls, equipped with a functional rim suitable for the installation of a countertop tap, or as a functional support surface.

Lavabo à poser avec bac intégré réalisé à partir de deux parois inclinées opposées à deux perpendiculaires, équipé d'un bord fonctionnel utilisé pour l'installation d'un mitigeur ou simplement comme base d'appui.

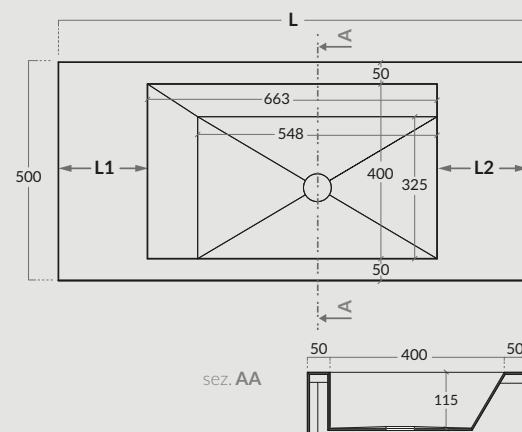

DIMENSIONI / DIMENSIONS / DIMENSIONS



LT01 **TWOSIDE**

design **Studio Solido**

LAVABO A MURO  
WALL-HUNG WASHBASIN  
LAVABO MURAL







# PIANI LAVABO E LAVABI IN APPOGGIO

Vanity top and washbasin / Plan sans bac et lavabo à poser



TOP LAVABO  
VANITY TOP  
PLAN VASQUE



# 1001 PLANO

design **Studio interno Nami**

**Top lavabo a muro o in appoggio con misure personalizzabili. Struttura in pannelli alleggeriti.**

Wall-hung or countertop washbasin with customizable sizes. Structure based on lightened panels.

Lavabo mural ou à poser sur meuble aux mesures personnalisées. Structure en panneaux allégés.

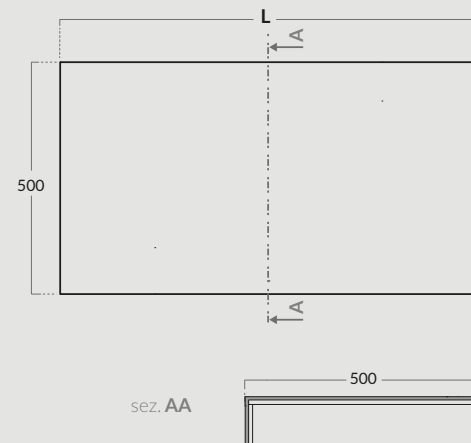

DIMENSIONI / DIMENSIONS / DIMENSIONS

TOP LAVABO  
VANITY TOP  
PLAN VASQUE

BUILT YARD  
NATURALE/MATT



PAVIMENTO  
FLOOR  
SOL

SAGE GREEN  
LUCIDATO



120x278 cm  
47<sup>1/16</sup> x 109<sup>7/16</sup>''

RIVESTIMENTO  
WALL TILING  
REVÊTEMENT

SAGE GREEN  
LUCIDATO



120x278 cm  
47<sup>1/16</sup> x 109<sup>7/16</sup>''

BUILT PATH  
NATURALE/MATT

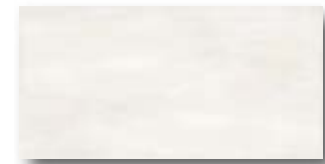

120x278 cm  
48" x 109<sup>23/64</sup>''

**Top a muro o appoggio, dall'aspetto monolitico, come a suggerire una scultura ricavata da un unico monoblocco marmoreo.**

Top washbasin featuring a monolithic aspect, recalling a sculpture made from a single marble block.

Plan sans bac ou à poser à l'aspect monolithique, comme une sculpture issue à partir d'un bloc de marbre.



LAVABO DA PIANO  
 COUNTERTOP WASHBASIN  
 LAVABO A POSER



# AP01 PRISM

design **Studio Solido**

Lavabo in appoggio con struttura in pannelli alleggeriti.  
 Vasca integrata con scarico centrale e copri-piletta.

Countertop washbasin with structure based on lightened panels.  
 Integrated basin with central drain and drain cover.

Lavabo à poser avec structure en panneaux allégés.  
 Bac intégré avec écoulement central et bonde.

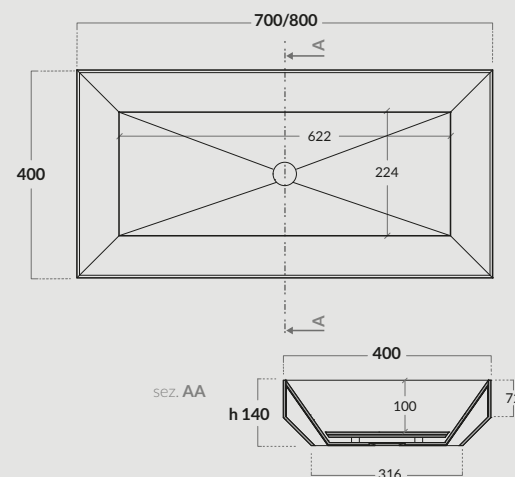

DIMENSIONI / DIMENSIONS / DIMENSIONS

LAVABO  
 WASHBASIN  
 LAVABO

CORE TEPHRA  
 NATURALE/MATT



PAVIMENTO  
 FLOOR  
 SOL

ARTHIS NATUR CHEVRON  
 NATURALE/MATT



20x100 cm  
 8'x40'

RIVESTIMENTO  
 WALL TILING  
 REVÊTEMENT

CORE ORIGINAL  
 NATURALE/MATT



120x120 cm  
 47 2/8 x 47 2/8"

Lavabo da piano dal design raffinato che si ispira alla sofisticata lavorazione delle pietre preziose, in cui il materiale di costruzione raggiunge la sua massima espressività attraverso la sapiente ed unica tecnologia costruttiva.

Countertop washbasin offering a refined design inspired by the sophisticated processing of precious stones, where the building material attains its highest expression through a wise and skilled building technology.

Lavabo à poser au design raffiné qui s'inspire au façonnage sophistiqué des pierres précieuses où le matériau rejoint sa meilleure expression au travers d'une unique et sensée technologie de construction.



# AW01 WASH HOUSE

design **Roberto Semprini**

Un'elegante geometria minimale in ceramica che, all'occorrenza, può accogliere due eleganti ali in TEAK portatrici di ulteriori funzioni.

Minimal geometry and elegance characterize this ceramic washbasin. Upon request it can be integrated with two elegant teak wood side wings offering new functions.

Une élégante géométrie minimaliste en céramique peut toutefois accueillir deux ailes élégantes en TEAK, porteuses d'ultérieures fonctions.

LAVABO DA PIANO  
COUNTERTOP WASHBASIN  
LAVABO A POSER



LAVABO  
WASHBASIN  
LAVABO

PORTRAITS KIRKBY  
NATURALE/MATT



PAVIMENTO  
FLOOR  
SOL

PORTRAITS KIRKBY  
NATURALE/MATT



60x120 cm  
23<sup>5/8</sup>"x47<sup>7/8</sup>"

RIVESTIMENTO  
WALL TILING  
REVÊTEMENT

ANIMA SELECT BIANCO ARABESCO  
LUCIDATO MACCHIA APERTA



120x278 cm  
48"x109<sup>29/64</sup>"

Lavabo in appoggio con struttura in gres accoppiato. Scarico centrale. Elementi laterali opzionali realizzati in legno TEAK.

Countertop washbasin with coupled porcelain stoneware structure. Central drain. Optional side elements made of TEAK.

Lavabo à poser avec structure en grès accouplé. Écoulement central. Éléments latéraux en option réalisés en TEAK.

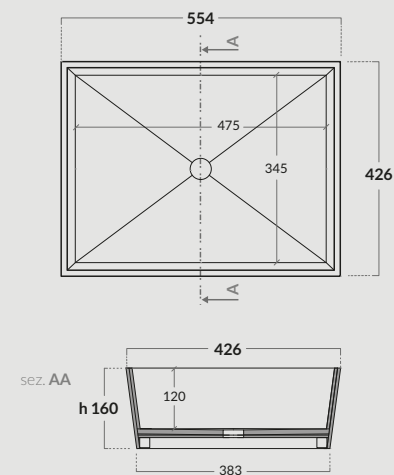

DIMENSIONI / DIMENSIONS / DIMENSIONS







LAVABO DA PIANO  
 COUNTERTOP WASHBASIN  
 LAVABO A POSER



# AF01 FOLD

design **Studio interno Nami**

Lavabo in appoggio che, grazie alla sua forma, coniuga design e funzionalità rendendosi adatto per ogni tipo di ambiente.

Countertop washbasin which, thanks to its shapes, combines design and functionality making it suitable for any location.

Lavabo à poser avec sa forme, allie design et fonctionnalité, convient à tout type de lieux

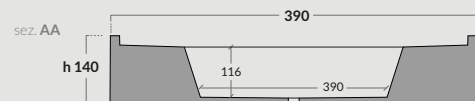
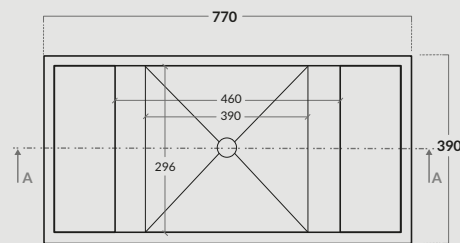

DIMENSIONI / DIMENSIONS / DIMENSIONS

LAVABO  
 WASHBASIN  
 LAVABO

NERO ATLANTE  
 LUCIDATO



PAVIMENTO  
 FLOOR  
 SOL

EVOOD PICK  
 NATURALE/MATT



20x120 cm  
 47 2/8" x 7 7/8"

RIVESTIMENTO  
 WALL TILING  
 REVÊTEMENT

AUTORE RIVOLI  
 NATURALE/MATT



120x278 cm  
 48"x109 29/64"

Lavabo in appoggio con struttura in pannelli alleggeriti rivestita in gres. Ripiani porta-oggetti integrati nel lavabo. Scarico centrale

Countertop washbasin with a structure that is based on lightened panels and covered in ceramic. Integrated shelves in the sink to store objects. central drain

Lavabo à poser avec structure recouverte de panneaux allégés en grès céramique. Tablettes porte-objets intégrées dans l'évier. Vidage central.





## BICOLOR

L'ampia gamma di colori ci permette di creare un livello di personalizzazione ancora più elevato: sarà possibile realizzare l'interno della vasca con un colore differente da quello del top creando un effetto cromatico innovativo ed elegante. L'opzione è disponibile per i modelli Simply, Basic e Fold.

The wide range of colors allows us to create a high level of customization: even higher than usual. It will be possible to create and integrate washbasin using a different color of the worktop, creating an innovative and elegant chromatic effect. This option is available only for Simply, Basic and Fold models.

La vaste gamme de couleurs nous permet de créer un niveau de personnalisation encore plus élevé : il sera possible de créer l'intérieur de la vasque avec une couleur différente de celle-lui du table, créant un effet chromatique innovant et élégant. Cette option sera disponible seulement pour les modèles Simply, Basic et Fold.





# PIATTI DOCCIA

Shower tray / Receveur de douche





# PC01 SIGN

design **Studio Solido**

**Piatto doccia interamente realizzato in gres a basso spessore con possibilità di installazione anche a filo pavimento. Il progetto consente l'abbinamento a rivestimenti o pavimenti dello stesso materiale creando superfici con soluzione di continuità.**

This shower tray is entirely made of low-thickness porcelain stoneware and is ideal for flush-floor installations. This product can be designed and combined with already existing coatings or floors, thus creating continuous surfaces with no interruptions.

Receveur de douche entièrement réalisé en grès de fine épaisseur ayant aussi la possibilité d'une installation à fleur de sol. Le projet permet l'assortiment des revêtements muraux et des sols avec les mêmes matériaux en créant une cohésion des surfaces et il permet en outre.

PIATTO DOCCIA  
SHOWER TRAY  
RECEVEUR DE DOUCHE



PIATTO DOCCIA  
SHOWER TRAY  
RECEVEUR DE DOUCHE

PORTRAITS COMBIANCHIEN  
NATURALE/MATT

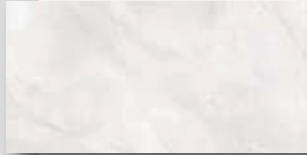

PAVIMENTO  
FLOOR  
SOL

EVOOD PICK  
NATURALE/MATT



20x120 cm  
47 2/8" x 7 1/8"

RIVESTIMENTO  
WALL TILING  
REVÊTEMENT

PORTRAITS COMBIANCHIEN  
NATURALE/MATT

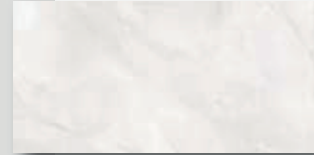

120x278 cm  
48"x109 29/64"

**Piatto doccia con scarico lineare ispezionabile. Struttura in pannelli alleggeriti. Altezza 30/60 mm.**

Shower tray with linear inspectionable drain. Structure based on lightened panels. 30/ 60 mm-high.

Receveur de douche avec écoulement linéaire amovible. Structure en panneaux allégés. Hauteur 30/60 mm

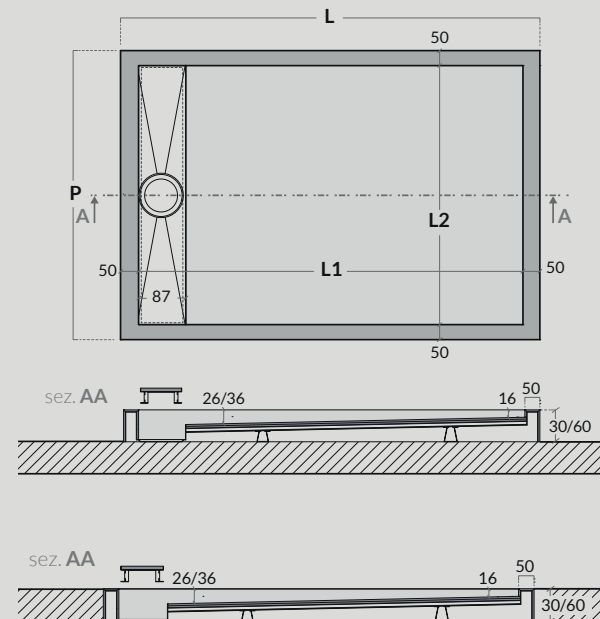

DIMENSIONI / DIMENSIONS / DIMENSIONS



# PS01 CORNER

design **Studio interno Nami**

Piatto doccia interamente realizzato in gres a basso spessore con possibilità di installazione anche a filo pavimento. Il progetto consente l'abbinamento a rivestimenti o pavimenti dello stesso materiale creando superfici con soluzione di continuità e permette inoltre di realizzare piatti su misura destinati a spazi privati ed ambienti contract.

This shower tray is entirely made of low-thickness porcelain stoneware and is ideal for flush-floor installations. This product can be designed and combined with already existing coatings or floors, thus creating continuous surfaces with no interruptions. We can also supply customized trays for private customers or contract solutions.

Receveur de douche entièrement réalisé en grès de fine épaisseur ayant aussi la possibilité d'une installation à fleur de sol. Le projet permet l'assortiment des revêtements muraux et des sols avec les mêmes matériaux en créant une cohésion des surfaces et il permet en outre, de réaliser des receveurs sur mesure destinés aux espaces privés ou projets clés-en-main.

PIATTO DOCCIA  
SHOWER TRAY  
RECEVEUR DE DOUCHE



PIATTO DOCCIA  
SHOWER TRAY  
RECEVEUR DE DOUCHE

PORTRAITS KIRKBY  
NATURALE/MATT



PAVIMENTO  
FLOOR  
SOL

PORTRAITS KIRKBY  
NATURALE/MATT



160x160 cm  
63"x63"

RIVESTIMENTO  
WALL TILING  
REVÊTEMENT

BUILT YARD  
NATURALE/MATT



160x320 cm  
63"x126"

Piatto doccia con scarico ispezionabile. Struttura in pannelli alleggeriti. Altezza 30/60 mm.

Shower tray with inspectionable drain. Structure based on lightened panels. 30/60 mm-high.

Receveur de douche avec écoulement amovible. Structure en panneaux allégés. Hauteur 30/60 mm

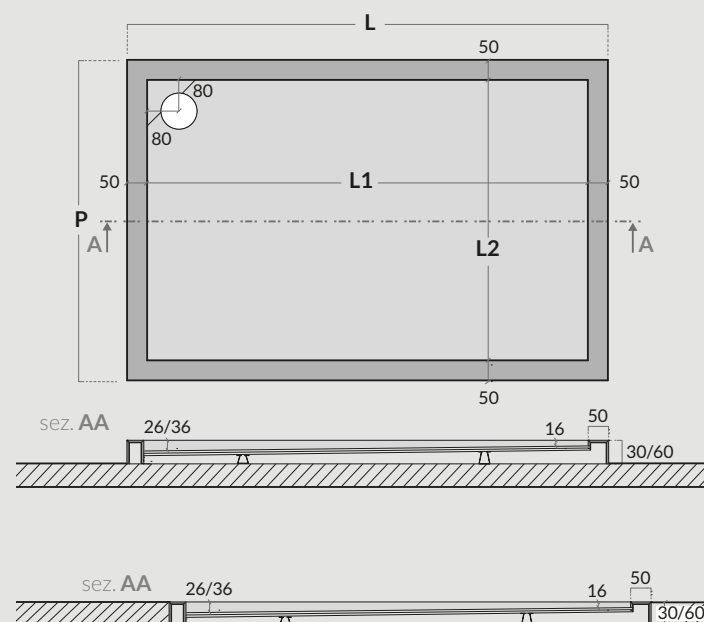

DIMENSIONI / DIMENSIONS / DIMENSIONS



# TAILOR MADE



Le lastre in Grès Porcellanato utilizzate come finitura di lavabi, top e piatti doccia derivano dalla ricerca di Ceramiche Caesar, storico produttore di Grès per pavimenti e rivestimenti. Forte di questa collaborazione, NAMI è in grado di proporre ai suoi clienti una vasta gamma di superfici coordinate con le finiture di arredo. Le molteplici combinazioni tra colori, look, superfici e formati consentono un ventaglio di possibilità notevolmente ampio; soluzioni di avanguardia estetica in grado di soddisfare ogni gusto.

Inoltre NAMI è in grado di rispondere alla crescente necessità di fornire un avanzato servizio di personalizzazione. Le sue competenze e le professionalità tecniche consentono laddove necessario di proporre soluzioni per arredi e spazi tailor-made, corredate da disegni e visual: questa virtù sartoriale va ad abbinarsi con un'importante capacità industriale, per offrire il servizio migliore a seconda delle necessità, per ogni progetto contract, retail o residenziale.

The porcelain stoneware slabs used for finishing washbasins, tops and showers are the outcome of the research conducted by Ceramiche Caesar, renowned manufacturer of stoneware for floors and walls. Thanks to this cooperation, Nami can offer its customers a broad range of surfaces that match with furniture. The many combinations of colours, looks and sizes give you such a wide selection of options to choose from; cutting-edge aesthetic solutions for any taste.

Furthermore, Nami can cater for the growing demand for customised services. The expertise and technical know-how make it possible to suggest solutions for tailor-made furniture and spaces, with the provision of drawings and visual layouts: the craftsmanship of a tailor combined with great industrial capabilities to give you the best service for your needs and for any contract, retail or residential project.

Les dalles en grès cérame utilisées pour la finition des vasques ou lavabos, tops et récepteur de douches ont été créées par le service Recherche et Développement du groupe Caesar, fabricant de renommée pour la production de grès pour le carrelage au sol et mural. Fort de cette collaboration, NAMI est en mesure de proposer à ses clients une gamme étendue de produits coordonnés pour la décoration des salles de bains. De multiples combinaisons, de couleurs, d'aspects, de surfaces et de formats permettent de très nombreuses applications : des solutions esthétiques très innovantes en mesure de satisfaire tous les goûts.

De plus, NAMI est en mesure de satisfaire un service de personnalisation. Ses compétences et son professionnalisme technique interviennent là où il est nécessaire de proposer des solutions individualisées accompagnées de dessins et visuels. À cette qualité du sur-mesure il convient d'ajouter une importante capacité industrielle pour offrir le meilleur service possible selon les nécessités pour chaque projet, chaque contrat, tant pour le magasin que pour le client final.



## ANIMA

Statuario Venato



9 mm	119,5x239 cm - 47 1/16"x94 1/8"	▲
6 mm	119,5x278 cm - 47 1/16"x109 7/16"	▲
6 mm	160x160 cm - 63"x63"	▲❖
6 mm	160x320 cm - 63"x126"	▲❖

## ANIMA

Calacatta Oro



9 mm	119,5x239 cm - 47 1/16"x94 1/8"	▲
6 mm	119,5x278 cm - 47 1/16"x109 7/16"	▲
6 mm	160x160 cm - 63"x63"	▲❖
6 mm	160x320 cm - 63"x126"	▲❖

## ANIMA EVER

Apuan Gold



6 mm	119,5x278 cm - 47 1/16"x109 7/16"	▲
6 mm	160x320 cm - 63"x126"	❖

## ANIMA EVER

Invisible Light



6 mm	119,5x278 cm - 47 1/16"x109 7/16"	▲
6 mm	160x320 cm - 63"x126"	❖

## ANIMA EVER

Supreme White



6 mm	119,5x278 cm - 47 1/16"x109 7/16"	▲
------	-----------------------------------	---

## ANIMA EVER

Luxury Arabesque



6 mm	119,5x278 cm - 47 1/16"x109 7/16"	▲
------	-----------------------------------	---

## ANIMA EVER

Royal Onyx



6 mm	119,5x278 cm - 47 1/16"x109 7/16"	▲
------	-----------------------------------	---

## ANIMA EVER

Sage Green



6 mm	119,5x239 cm - 47 1/16"x94 1/8"	▲
------	---------------------------------	---

## ANIMA SELECT

Bianco Arabesco



9 mm	119,5x239 cm - 47 1/16"x94 1/8"	▲
6 mm	119,5x278 cm - 47 1/16"x109 7/16"	▲
6 mm	160x160 cm - 63"x63"	▲❖
6 mm	160x320 cm - 63"x126"	▲❖

## ANIMA SELECT

Nero Atlante



6 mm	119,5x278 cm - 47 1/16"x109 7/16"	▲
6 mm	160x160 cm - 63"x63"	▲❖
6 mm	160x320 cm - 63"x126"	▲❖

## BUILT

Yard



6 mm	119,5x278 cm - 47 1/16"x109 7/16"	●
6 mm	160x160 cm - 63"x63"	●
6 mm	160x320 cm - 63"x126"	●

## BUILT

Dam



6 mm	119,5x278 cm - 47 1/16"x109 7/16"	●
------	-----------------------------------	---

## BUILT

Path



6 mm	119,5x278 cm - 47 1/16"x109 7/16"	●
------	-----------------------------------	---

## PORTRAITS

Faro



9 mm	119,5x239 cm - 47 1/16"x94 1/8"	●
6 mm	119,5x278 cm - 47 1/16"x109 7/16"	●
6 mm	160x160 cm - 63"x63"	●
6 mm	160x320 cm - 63"x126"	●

## PORTRAITS

Kirkby



9 mm	119,5x239 cm - 47 1/16"x94 1/8"	●
6 mm	119,5x278 cm - 47 1/16"x109 7/16"	●
6 mm	160x160 cm - 63"x63"	●
6 mm	160x320 cm - 63"x126"	●

## PORTRAITS

Comblanchien



6 mm	119,5x239 cm - 47 1/16"x94 1/8"	●
------	---------------------------------	---

## RELATE

Blizzard (Flame)



6 mm	119,5x278 cm - 47 1/16"x109 7/16"	●
------	-----------------------------------	---

## RELATE

Mine (Flame)



6 mm	119,5x278 cm - 47 1/16"x109 7/16"	●
------	-----------------------------------	---

## RELATE

Reef (Flame)



6 mm	119,5x278 cm - 47 1/16"x109 7/16"	●
------	-----------------------------------	---

## RELATE

Moos (Flame)



6 mm	119,5x278 cm - 47 1/16"x109 7/16"	●
------	-----------------------------------	---

## RELATE

Blaze (Flame)



6 mm	119,5x278 cm - 47 1/16"x109 7/16"	●
------	-----------------------------------	---

## BEMORE

Chill



6 mm	160x160 cm - 63"x63"	●
6 mm	160x320 cm - 63"x126"	●

## BEMORE

Haze



6 mm	160x160 cm - 63"x63"	●
6 mm	160x320 cm - 63"x126"	●

## ONE

Cement



9 mm	119,5x239 cm - 47 1/16"x94 1/8"	●
------	---------------------------------	---

## TRACE

Mint



9 mm	119,5x239 cm - 47 1/16"x94 1/8"	●
6 mm	119,5x278 cm - 47 1/16"x109 7/16"	●
6 mm	160x160 cm - 63"x63"	●
6 mm	160x320 cm - 63"x126"	●

## JOIN

Glare

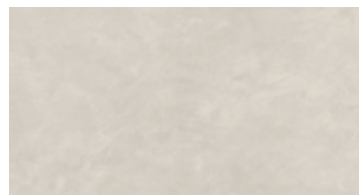

6 mm	119,5x278 cm - 47 1/16"x109 7/16"	▲
------	-----------------------------------	---

## JOIN

Wing



6 mm	119,5x278 cm - 47 1/16"x109 7/16"	▲
------	-----------------------------------	---

## JOIN

Levity



6 mm	119,5x278 cm - 47 1/16"x109 7/16"	▲
------	-----------------------------------	---

## TINTE UNITE

Purewhite

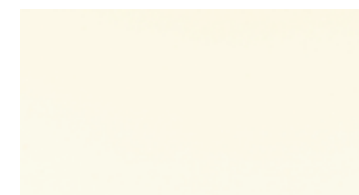

6 mm	160x160 cm - 63"x63"	●
6 mm	160x320 cm - 63"x126"	●

- Naturale
- ▲ Lucidato
- ❖ Silk

Il tono del gres ceramico utilizzato per realizzare il manufatto (es lavabo - piatto doccia) è simile ma non uguale al fondo ceramico eventualmente utilizzato per rivestire la parete adnessa. Qualora si desidera la stessa tonalità dovrà essere indicato in forma scritta al momento della trasmissione dell'ordine. La richiesta sarà evasa nei limiti della disponibilità dei prodotti dello stesso tono e lotto a magazzino.

I colori dei materiali illustrati all'interno del presente Catalogo non sempre corrispondono a quelli reali per comprensibili motivi di stampa. Colori e tonalità si possono visionare presso i Punti Vendita, direttamente su prodotti e campionari.

The tone of the porcelain stoneware used to make these products (eg washbasin, shower tray...) is similar but not the same as the porcelain base used to cover the wall or floor. If you want the same shade needs to be written at the time of order. The request will be processed within the limits of the availability of products of the same tone and lot in stock.

The colours referring to the materials illustrated inside this catalogue do not always correspond to the real ones for obvious printing reasons. Colours and shades can be seen at the Points of Sale, directly on materials and sample sets.

Le ton du grès cérame utilisé pour fabriquer ces produits (lavabo, receveur de douche, etc.) est similaire, mais pas le même que celui de la base en céramique utilisée pour revêtir le mur ou le sol. Si vous voulez, la même nuance doit être écrite au moment de la commande. La demande sera traitée dans la limite de la disponibilité des produits du même ton et lot en stock.

En raison de certaines contraintes d'impression, les coloris des matériaux illustrés dans ce catalogue ne correspondent pas toujours aux coloris réels. Vous pouvez voir les coloris et les teintes dans les Points de vente, directement sur les produits ou sur des échantillons.



**CREDITS**

This catalogue has been  
made by NAMI  
in collaboration with

**Graphic design**

Daniele Feligioni

**Photography**

Livio Fantozzi

Images by NAMI archive

**Styling**

Laura Tondi

**Photolithographs**

Selecolor Firenze

**Print**

Grapho5



## **NAMI**

VIA DEI TRASPORTI, S.N.  
LOC. CHIUSA DI GINESTRETO  
61122 PESARO - ITALY  
T. +39 0721 482684/482541  
F. +39 0721 482475/482018  
[WWW.NAMIBATH.COM](http://WWW.NAMIBATH.COM)